

## PUSHBUTTONS

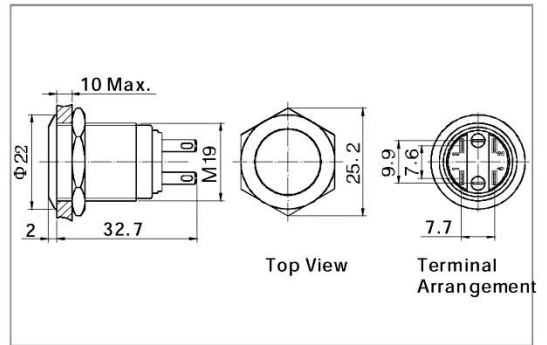

AVSLAS1GQ-11□

- ⊙ Φ 19mm diameter
- ⊙ 5A/250VAC
- ⊙ 1NO1NC
- ⊙ Front Shape: Flat Round
- ⊙ Crust material: Stainless Steel
- ⊙ IP Degree: IP65



## KEY SWITCHES



AVSLAS1GQ-□□Y

- ⊙ Φ 19mm diameter
- ⊙ 5A/250VAC
- ⊙ 1NO1NC/2NO2NC
- ⊙ Two position remain
- ⊙ Crust material: Stainless Steel
- ⊙ IP Degree: IP40

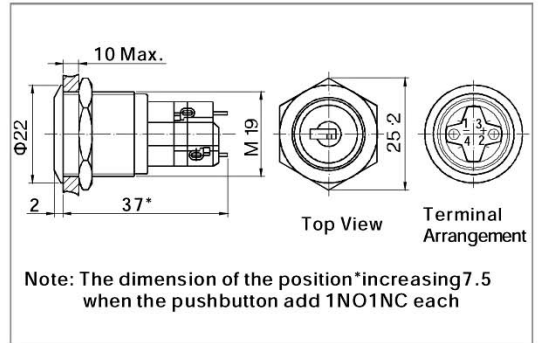

Specification	AVSLAS1GQ-11 □	AVSLAS1GQ- □□Y
The Front Shape	Flat Round	Round
Terminal Type	Pin Terminal(2.8×0.5mm)	Pin Terminal
Switching	No.2	No.2
Max. Switch Rating	5A/250VAC	5A/250VAC
Contact Resistance	≤ 50mΩ	≤ 50mΩ
Insulation Resistance	≥ 1000MΩ	≥ 1000MΩ
Dielectric Strength	2000VAC	2000VAC
Operation Temp.	-20°C ~ +70°C	-20°C ~ +70°C
Mechanical Life	1,000,000cycles	1,000,000cycles
Electrical Life	50,000 cycles	50,000 cycles
Contact Material	Silver Alloy	Silver Alloy
Panel Thickness	1 ~ 10mm	1 ~ 10mm
Torque	5 ~ 14Nm	5 ~ 14Nm
Operation Pressure	3~8N	3~8N
IP Degree	IP65	IP40
Material	Button	Stainless Steel
	Body	Stainless Steel
	Base	PBT
RoHS	Made to order	Made to order

Introduction of product model refer to P1